

|              |      |     |  |
|--------------|------|-----|--|
| CI/SfB       | (21) | Xt6 |  |
| January 2021 |      |     |  |

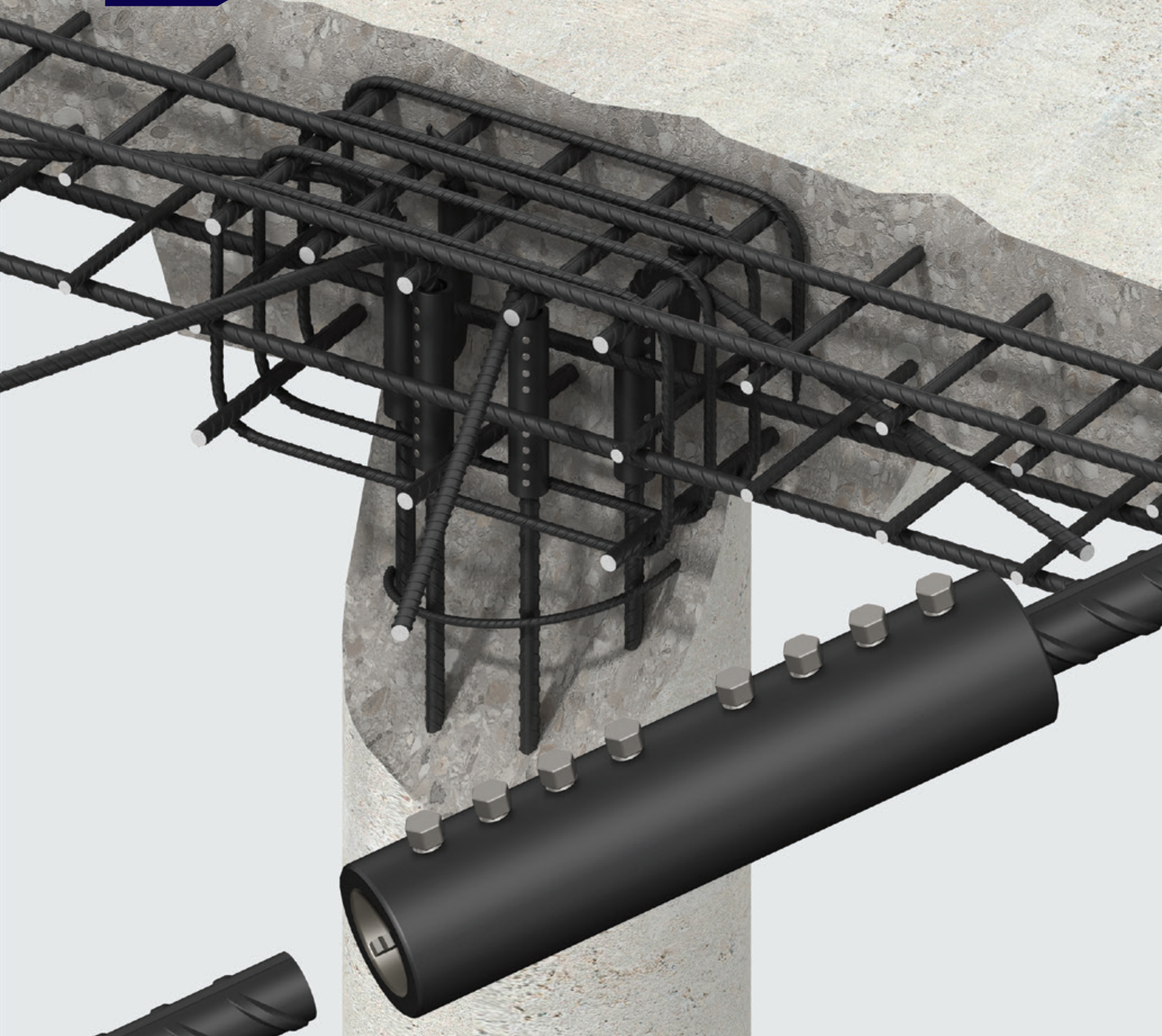

# Ancon<sup>®</sup>

## MBT Mechanically-Bolted Couplers

for the Construction Industry



# **We are one team.** **We are Leviat.**

Leviat is the new name of CRH's construction accessories companies worldwide.

Under the Leviat brand, we are uniting the expertise, skills and resources of Ancon and its sister companies to create a world leader in fixing, connecting and anchoring technology.

The products you know and trust will remain an integral part of Leviat's comprehensive brand and product portfolio. As Leviat, we can offer you an extended range of specialist products and services, greater technical expertise, a larger and more agile supply chain and better, faster innovation.

By bringing together CRH's construction accessories family as one global organisation, we are better equipped to meet the needs of our customers, and the demands of construction projects, of any scale, anywhere in the world.

**This is an exciting change. Join us on our journey.**

**Read more about Leviat at [Leviat.com](https://www.leviat.com)**



Our product brands include:

**Ancon**

  
**HALFEN**

**HELIFIX** 

 **ISEDIO**

**PLAKA**



**60**  
locations

sales in  
**30+**  
locations

**3000**  
people worldwide

Imagine. Model. Make.

[Leviat.com](http://Leviat.com)



# Reinforcing Bar Couplers

## Simplify the design and construction of concrete

Lapped joints are not always an appropriate means of connecting reinforcing bars. The use of laps can be time consuming in terms of design and installation and can lead to greater congestion within the concrete because of the increased amount of rebar used.

Ancon couplers can simplify the design and construction of reinforced concrete and reduce the amount of reinforcement required.

Lapped joints are dependent upon the concrete for load transfer. For this reason any degradation in the integrity of the concrete could significantly

affect the performance of the joint. The strength of a mechanical splice is independent of the concrete in which it is located and will retain its strength despite loss of cover as a result of impact damage or seismic event.

Our range of Ancon reinforcing bar couplers is the most comprehensive available and includes tapered threaded, parallel threaded, mechanically bolted and grouted couplers.

Couplers for stainless steel and cryogenic-grade rebars complete the range.

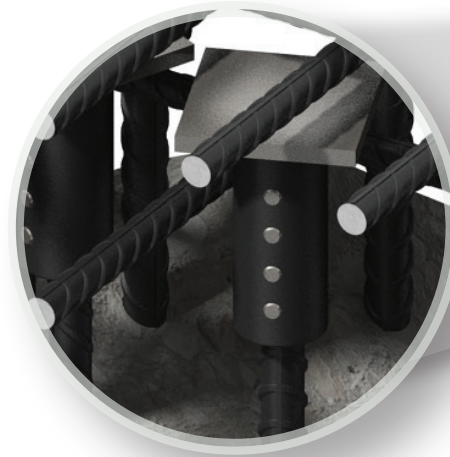
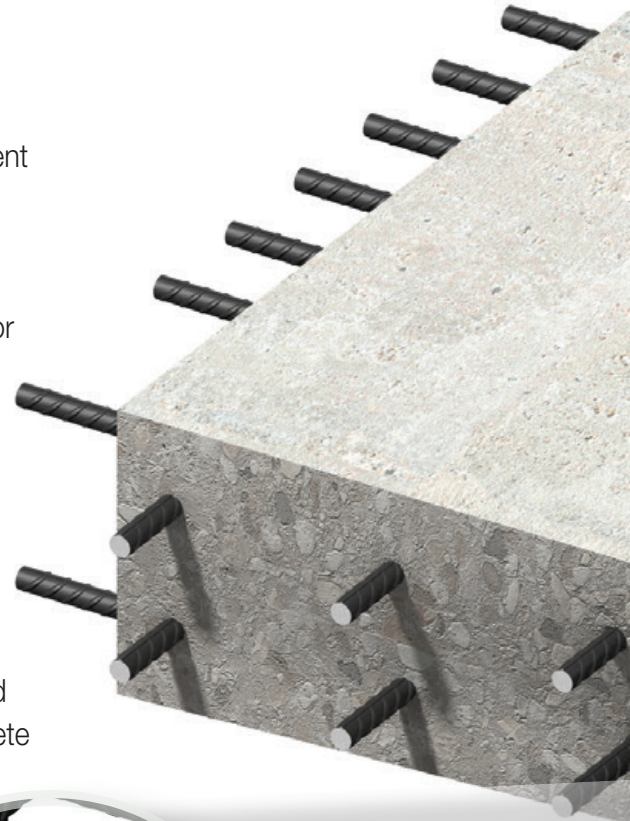

## Contents

|                                 |          |
|---------------------------------|----------|
| <u>MBT ET Series</u>            | <u>4</u> |
| <u>MBT Transition Series</u>    | <u>5</u> |
| <u>MBT Continuity Series</u>    | <u>6</u> |
| <u>Repair and Remedial Work</u> | <u>7</u> |
| <u>MBT Headed Anchors</u>       | <u>8</u> |
| <u>HM Grout Sleeve Couplers</u> | <u>9</u> |
| <u>Other Ancon Products</u>     | <u>9</u> |



THE QUEEN'S AWARDS  
FOR ENTERPRISE:  
INTERNATIONAL TRADE  
2015



THE QUEEN'S AWARDS  
FOR ENTERPRISE:  
INNOVATION  
2018



Eurocode 2 compliant



Simplify design and  
construction



ISO 9001, ISO 14001,  
OHSAS 18001



Available through major  
rebar stockists and  
approved distributors



Dedicated sales  
support



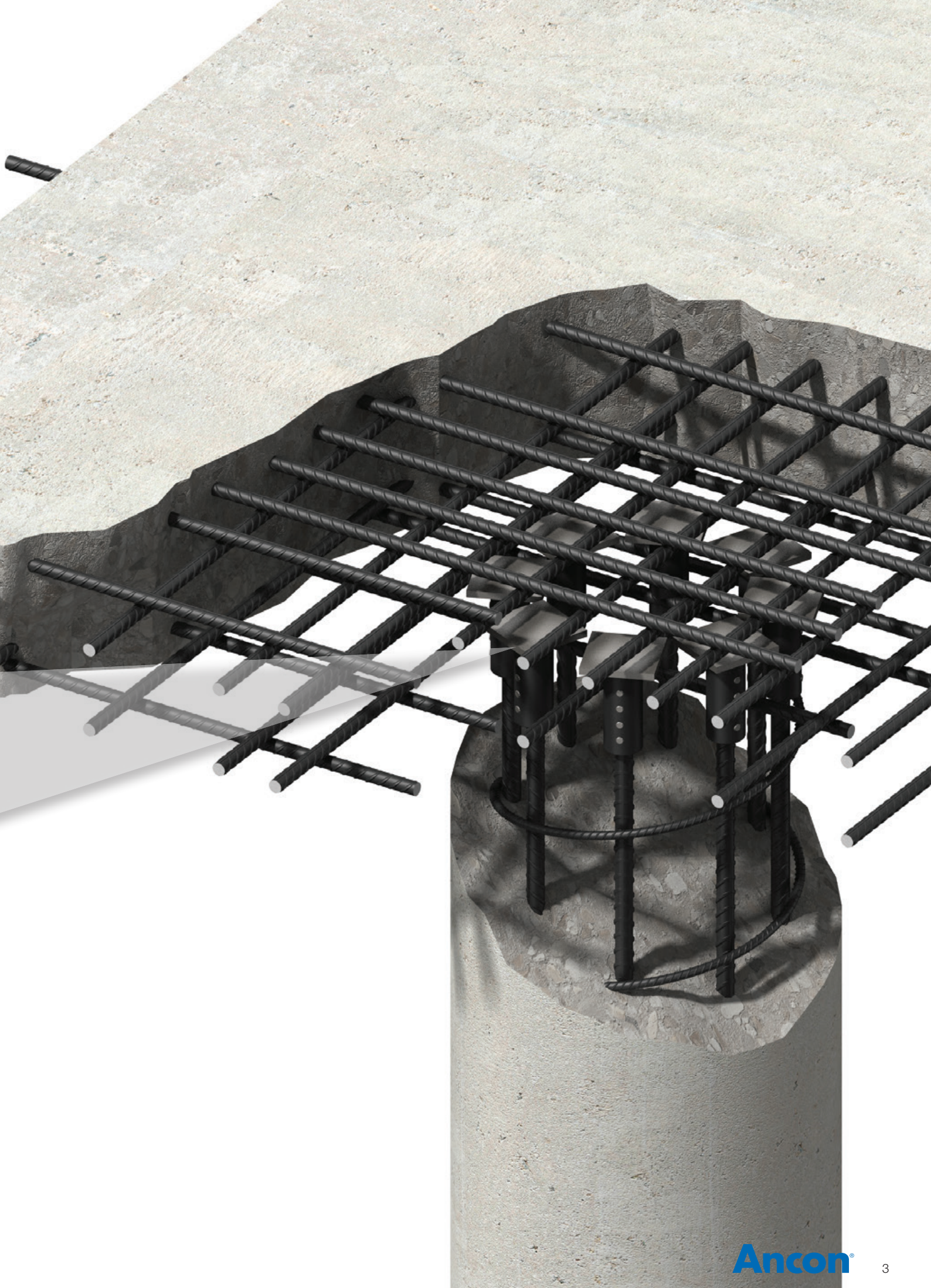



# Reinforcing Bar Couplers

## MBT

The Ancon MBT range of couplers provides a cost-effective method of joining reinforcing bars, particularly when the fixed bar is already in place and there is insufficient space for a hydraulic swaging press.

MBT Couplers are easy to install and achieve failure loads higher than 115% of the characteristic yield strength of grade 500 reinforcing bar. Neither bar end preparation to form threads, nor bar rotation are required. MBT couplers can also be used to join imperial, plain round or deformed reinforcing bars.

The bar ends are supported within the coupler by two serrated saddles, and as the lockshear bolts are tightened, the conical ends embed themselves into the bar. As this happens the serrated saddles bite into both the bar and the shell of the coupler. The lockshear bolts of couplers up to and including the ET20 can be tightened using a ratchet wrench. For larger couplers a nut runner is recommended.

In all cases heavy duty sockets should be used. When the pre-determined tightening torque for the bolts is reached, the heads shear off leaving the top of the installed bolt slightly proud of the coupler. This provides an instant visual check of correct installation.

**Note:** Impact tools must not be used to tighten lockshear bolts.

## MBT ET Series

The MBT ET series of couplers is used to connect reinforcing bars of the same size.

### Testing & Approvals

Full destructive tests are carried out on selected couplers from our stocks. MBT couplers are designed and manufactured in accordance with BS EN ISO 9001. The most common sizes of ET series couplers are approved by HAPAS (Highway Authorities Product Approval) covered by certificate 15/H240 issued by the BBA, including the bar sizes featured in the table below. Sizes ET10, 12, 14, 16, 20, 25 and 28 have been tested and approved by the DIBt and are covered by Approval No Z-1.5-10. Further national approvals include BMVIT Approval No. -327.120/0018-II/ST2/2006, RISE Approval No.0541-95 which covers the ET Series and Continuity C Series, and AFCAB Approval No. M20/023 which covers specific bar diameter sizes in the ET series of couplers, as shown in the table below.



The full range of MBT Couplers is certified by GOST for the Russian Federation. In addition the coupler has been tested to show compliance with the following international design codes:- BS EN 1992-1-1: 2004 (Eurocode 2), BS5400, BS8110, BS8597: 2015, ACI 318 and DIN 1045 German code.



**Note:** Not all coupler types and sizes are relevant to the national approvals shown. For details of coupler types and sizes relevant to each national approval please refer to the relevant approval document, which is available on request.

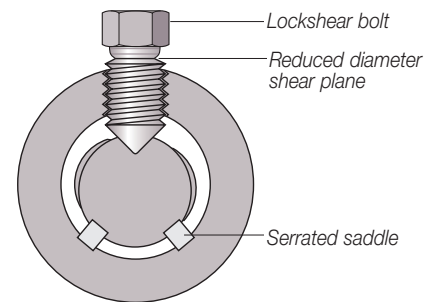

Section showing the embedment of the lockshear bolts and saddles into the bar and the shell of the coupler

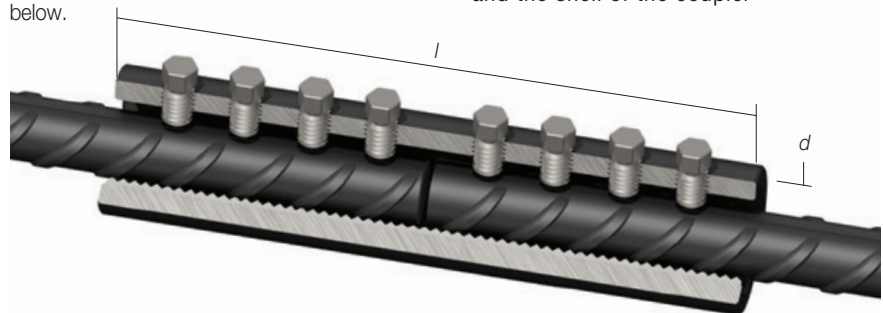

### MBT ET Series Dimensions

| Bar Diameter (mm)      |          | 10   | 12*  | 14*  | 16*   | 18   | 20*  | 22   | 25*  | 26   | 28   | 30   | 32*  | 34   | 36    | 40*   |
|------------------------|----------|------|------|------|-------|------|------|------|------|------|------|------|------|------|-------|-------|
| External Diameter (mm) | <i>d</i> | 33   | 33   | 42   | 42    | 48   | 48   | 48   | 54   | 67   | 67   | 71   | 71   | 75   | 85    | 81    |
| Total Length (mm)      | <i>l</i> | 100  | 140  | 160  | 160   | 204  | 204  | 248  | 258  | 312  | 312  | 312  | 312  | 420  | 484   | 484   |
| Socket Size A/F (ins)  |          | 1/2  | 1/2  | 1/2  | 1/2   | 1/2  | 1/2  | 1/2  | 5/8  | 5/8  | 5/8  | 5/8  | 5/8  | 3/4  | 3/4   | 3/4   |
| No. of Bolts           |          | 4    | 6    | 6    | 6     | 8    | 8    | 10   | 8    | 10   | 10   | 10   | 10   | 12   | 14    | 14    |
| Approx Weight (kg)     |          | 0.52 | 0.72 | 1.25 | 1.25  | 2.0  | 1.96 | 2.38 | 3.00 | 5.91 | 5.80 | 6.68 | 6.50 | 8.85 | 15.30 | 11.30 |
| Part No.               |          | ET10 | ET12 | ET14 | ET16* | ET18 | ET20 | ET22 | ET25 | ET26 | ET28 | ET30 | ET32 | ET34 | ET36  | ET40  |

**Note:** Dimensions are nominal values and subject to change from time to time. Other sizes available on request. For details contact us.

\* AFCAB certification applies to this bar diameter size

### Installation MBT ET Series

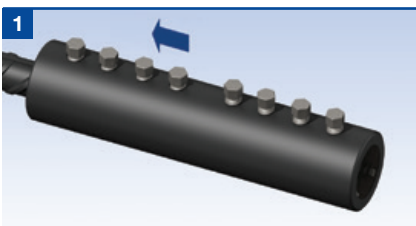

Place the coupler over the end of the bar to half the coupler length +/- 6mm and finger tighten the lockshear bolts onto the bar. Check the alignment and make any necessary adjustments.

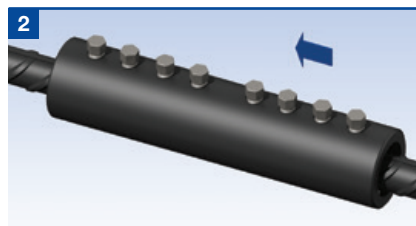

Place the other bar end into the coupler until it pushes up against the first bar and finger tighten the remaining lockshear bolts. Check alignment and make any adjustments.

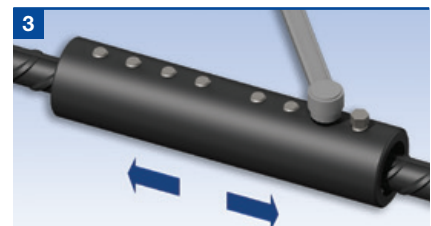

On one half of the coupler, starting from the centre and working outwards, partly tighten the lockshear bolts using either a ratchet wrench or a nut runner as appropriate. Do not use impact tools. Repeat again, this time fully tightening the lockshear bolts until the bolt heads shear off. Repeat the above for the other half of the coupler.

## MBT Transition Series

The Ancon MBT Transition series of couplers provides an effective solution for connecting bars of different diameters.

Transition couplers have all of the benefits of the ET series and are designed to achieve failure loads higher than 115% of the characteristic yield strength of the smaller grade 500 reinforcing bar.

They can be installed without any preparation to the bar ends and without any need to rotate bars.

The coupler can be rotated to allow access to the bolts for tightening with either a ratchet wrench or a nut runner. In all cases heavy duty sockets should be used. Transition couplers are non-standard and are made to order.

**Note:** Impact tools should not be used to tighten lockshear bolts.

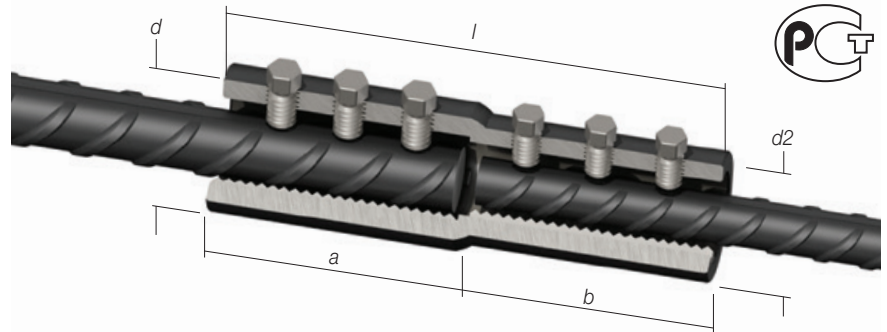

### MBT Transition Series Dimensions

| Bar Diameter (mm)      |            | 16/12   | 16/14   | 20/12   | 20/16   | 25/16   | 25/20   | 28/20   | 28/22   | 28/25   | 32/20   | 32/25   | 32/28   | 40/32   |
|------------------------|------------|---------|---------|---------|---------|---------|---------|---------|---------|---------|---------|---------|---------|---------|
| External Diameter (mm) | <i>d</i>   | 42      | 42      | 48      | 48      | 54      | 54      | 67      | 67      | 67      | 71      | 71      | 71      | 81      |
| External Diameter (mm) | <i>d2</i>  | 26      | 42      | 33      | 48      | 42      | 54      | 48      | 42      | 54      | 48      | 54      | 67      | 71      |
| Total Length (mm)      | <i>l</i>   | 160     | 160     | 150     | 160     | 155     | 180     | 204     | 253     | 258     | 177     | 231     | 286     | 335     |
| Individual Lengths     | <i>a:b</i> | 80:80   | 80:80   | 80:70   | 80:80   | 75:80   | 90:90   | 102:102 | 129:124 | 129:129 | 75:102  | 102:129 | 130:156 | 178:157 |
| Socket Size A/F (ins)  | <i>a:b</i> | 1/2:1/2 | 1/2:1/2 | 1/2:1/2 | 1/2:1/2 | 5/8:1/2 | 5/8:1/2 | 5/8:1/2 | 5/8:1/2 | 5/8:5/8 | 5/8:1/2 | 5/8:5/8 | 5/8:5/8 | 3/4:5/8 |
| No. of Bolts           | <i>a:b</i> | 3:3     | 3:3     | 3:3     | 3:3     | 2:3     | 3:3     | 3:4     | 4:5     | 4:4     | 2:4     | 3:4     | 4:5     | 5:5     |
| Approx Weight (kg)     |            | 1.30    | 1.25    | 1.13    | 1.56    | 1.51    | 2.23    | 2.94    | 3.61    | 3.98    | 2.55    | 3.70    | 5.71    | 7.47    |
| Part No.               |            | ET16/12 | ET16/14 | ET20/12 | ET20/16 | ET25/16 | ET25/20 | ET28/20 | ET28/22 | ET28/25 | ET32/20 | ET32/25 | ET32/28 | ET40/32 |

**Note:** Dimensions are nominal values and subject to change from time to time.

### Installation

#### MBT Transition Series

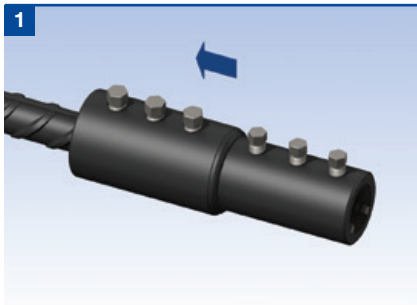

Place the coupler over the end of the bar to the appropriate depth +/- 6mm and finger tighten the lockshear bolts onto the bar. Check the alignment and make any necessary adjustments.

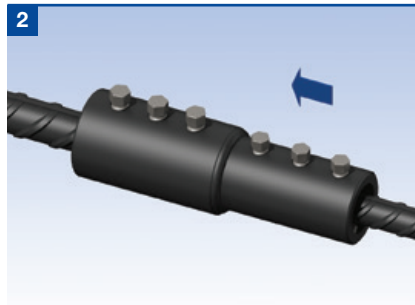

Place the other bar end into the coupler until it pushes up against the first bar and finger tighten the remaining lockshear bolts. Check alignment and make any adjustments.

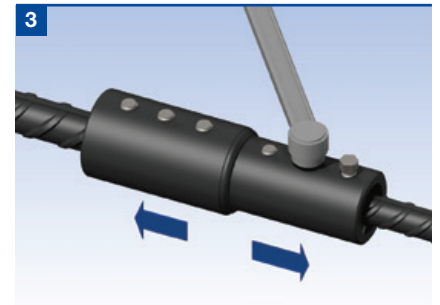

On one half of the coupler, starting from the centre and working outwards, partly tighten the lockshear bolts using either a ratchet wrench or a nut runner as appropriate. Do not use impact tools. Repeat again, this time fully tightening the lockshear bolts until the bolt heads shear off.

Repeat the above for the other half of the coupler.

### Electric Wrench

Ancon Electric Wrenches are available for purchase or hire. The smooth continuous action of the wrench prevents the early shearing of the lockshear bolts and damage to threads. The wrench is supplied with specially hardened heavy duty sockets. For details please contact us.



# Reinforcing Bar Couplers

## MBT Continuity C Series

The Ancon MBT Continuity coupler allows reinforcement to be extended at construction joints without the need to drill or otherwise substantially deface the formwork.



The female part of the C series coupler is fixed to the formwork with the aid of a nail plate.

After removal of the formwork, the nail plate protects the internally threaded end of the coupler. It is advisable to loosen the nail plate to break the bond with the concrete whilst it is still 'green'. When the nail plate is removed, the male section can be screwed into the existing section of the coupler.

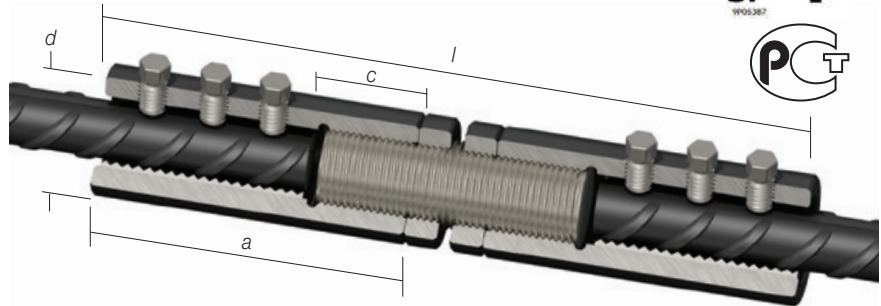

| Bar Diameter (mm)               |   | 12     | 16     | 20     | 25      | 32      | 40      |
|---------------------------------|---|--------|--------|--------|---------|---------|---------|
| External Diameter (mm)          | d | 33     | 42     | 48     | 54      | 71      | 81      |
| Maximum Length (mm)             | l | 250    | 280    | 349    | 414     | 490     | 675     |
| Female Component Length (mm)    | a | 100    | 115    | 147    | 177     | 214     | 300     |
| Threaded Section (mm)           | c | 30     | 35     | 38     | 43      | 53      | 53      |
| Socket Size A/F (ins)           |   | 1/2    | 1/2    | 1/2    | 5/8     | 5/8     | 3/4     |
| No. of Bolts                    |   | 6      | 6      | 8      | 8       | 10      | 14      |
| Nail Plate Diameter x Thickness |   | 75 x 5 | 75 x 5 | 75 x 5 | 100 x 5 | 100 x 5 | 127 x 5 |
| Approx Weight (kg)              |   | 1.40   | 2.20   | 3.70   | 5.15    | 11.5    | 18.8    |
| Part No.                        |   | C12    | C16    | C20    | C25     | C32     | C40     |

**Note:** Dimensions are nominal values and subject to change from time to time.

### Installation

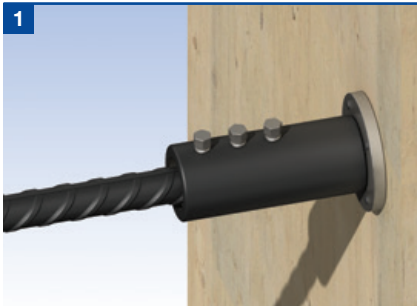

Fix the nail plate to the formwork and fully screw the female component onto the plate. Insert the bar into the coupler, ensuring that it does not encroach into the threaded section. Finger tighten the lockshear bolts. Check alignment and make any adjustments.

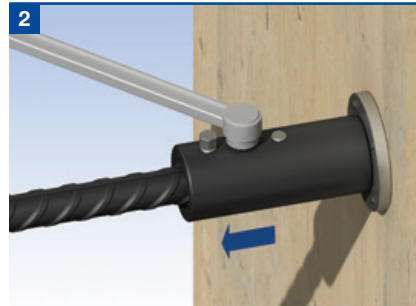

Starting from the nail plate end and working outwards, partly tighten the lockshear bolts using either a ratchet wrench or a nut runner as appropriate. Do not use impact tools. Repeat again, this time fully tightening the lockshear bolts until the bolt heads shear off. Cast in concrete.

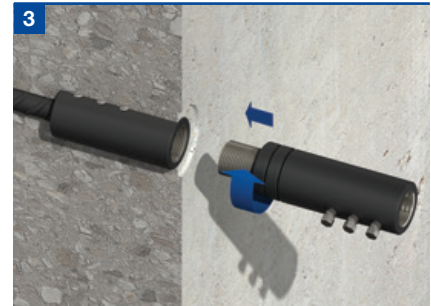

Remove the formwork and unscrew the nail plate. The male component can now be fully screwed into the fixed female component. The male component can be rotated up to a full turn to allow the bolts to be located in an accessible position for tightening.



Run the locknut along the threaded male stud to abut the female component. Fully tighten the locknut against the female section using a wrench.



Place the continuation bar into the male component and finger tighten the bolts. Check alignment and make any adjustments. Starting from the centre and working outwards, partly tighten the lockshear bolts using either a ratchet wrench or a nut runner as appropriate. Do not use impact tools. Repeat again, this time fully tightening the lockshear bolts until the bolt heads shear off. Fully tighten the locknut.

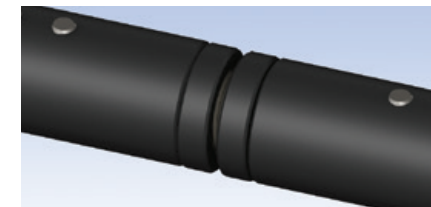

**Note:** When the coupler is fully assembled the visible threaded stud between the two locknuts must not exceed 20mm.

**Note:** The Continuity Coupler male component will be delivered with the threaded stud already in place and the locknuts located on the threaded stud. If the female component is to be left in situ for an extended period, the threads must be greased to prevent corrosion.



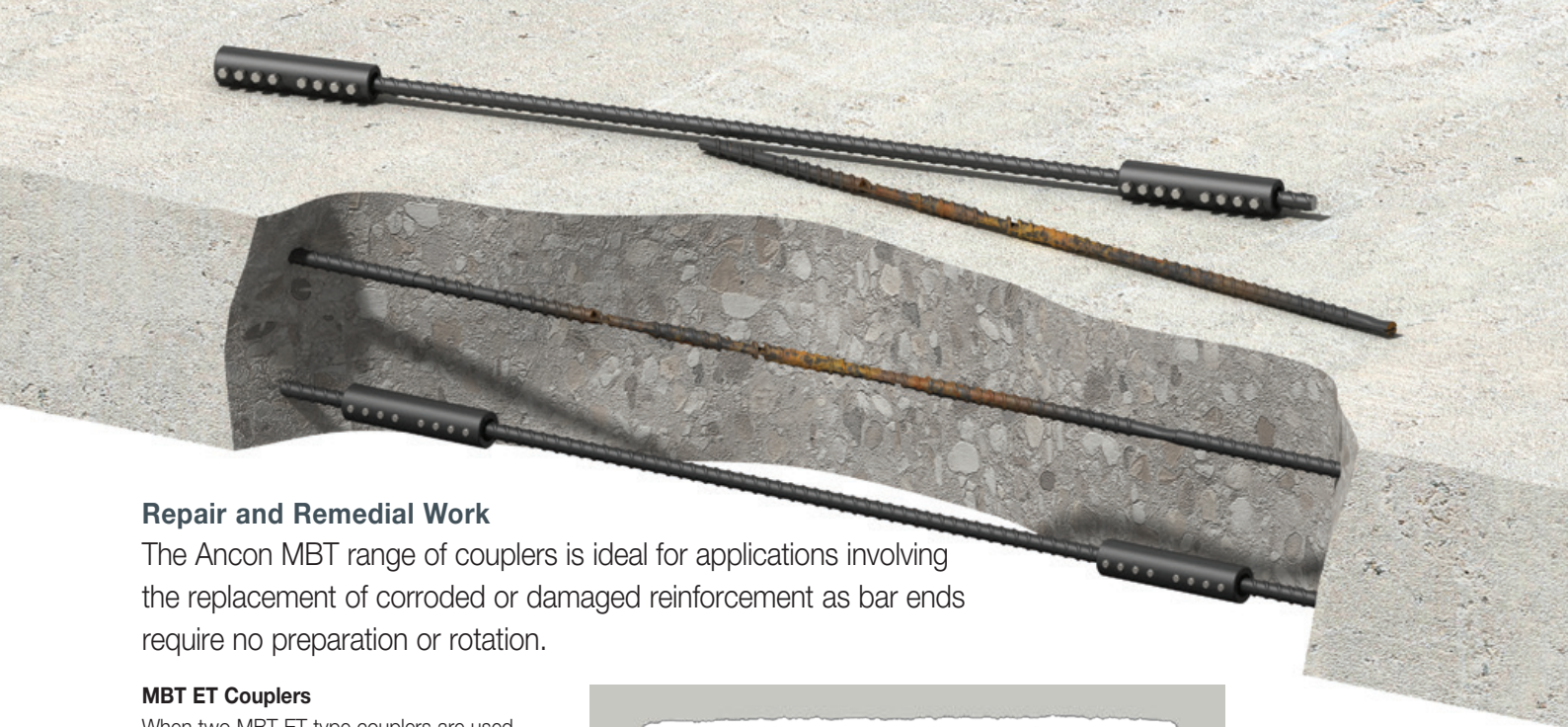

## Repair and Remedial Work

The Ancon MBT range of couplers is ideal for applications involving the replacement of corroded or damaged reinforcement as bar ends require no preparation or rotation.

### MBT ET Couplers

When two MBT ET type couplers are used, the replacement bar is cut approximately 5mm shorter than the original length to allow clearance for insertion between the sound ends of the in-situ bars. MBT ET couplers are pushed fully over both ends of the replacement bar and temporarily held in position. The replacement bar is then correctly positioned and the couplers moved to a previously marked position on the existing bars indicating half the length of the coupler. The lockshear bolts are tightened to complete the installation.

The above application is suitable where the bar being replaced is at least 2 x MBT ET coupler length (see page 22) + 100mm.

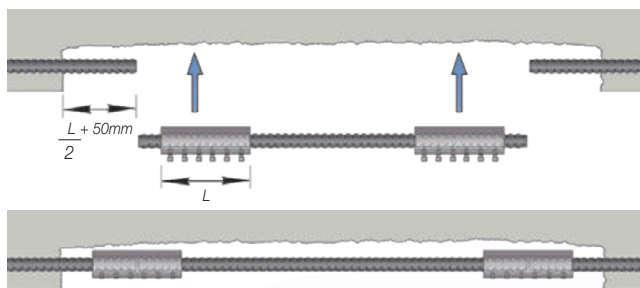

Bar replacement using two MBT ET Couplers



MBT Continuity C Series Gap Closer. Central threaded stud is modified to suit the gap.

### MBT Continuity C Series Gap Closer

A smaller section of bar can be removed and replaced by an MBT Continuity C Series coupler. The central threaded stud can be modified to suit the gap. The table provides the minimum bar length (dimension A) and minimum concrete pocket length (dimension B) to be cut away to facilitate this solution.

### MBT Continuity C Series Gap Closer

| Bar Diameter (mm) | Minimum Dimensions |     |
|-------------------|--------------------|-----|
|                   | A                  | B   |
| 12                | 100                | 300 |
| 16                | 115                | 345 |
| 20                | 147                | 441 |
| 25                | 177                | 531 |
| 32                | 214                | 642 |
| 40                | 300                | 900 |

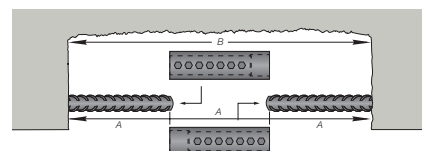

## Installation

### Bar replacement using MBT Continuity C Series Gap Closer



1 Orientate so threaded sections face inwards and pass the two halves of the continuity coupler over the opposing bar ends to leave the gap visible.



2 Insert appropriately sized stud in the gap and rotate each half of the coupler so the stud locates fully in each internal thread.



3 Tighten locknuts against the couplers. Shear bolt heads to complete installation by starting from the centre and working outwards and partly tightening the lockshear bolts using either a ratchet wrench or a nut runner as appropriate. Do not use impact tools. Repeat again, this time fully tightening the lockshear bolts.



# Reinforcing Bar Couplers



## MBT Headed Anchors

Ancon MBT Headed Anchors are designed to provide dead end embedment for bars in concrete. This helps to reduce congestion and simplify the placement of rebars by removing the need for hooked ends.

The anchor comprises half an MBT coupler with a plate welded to one end which carries the full tension load of the bar when it is bearing against the concrete. Plates can be supplied with or without a hole, allowing bars to either end in or pass through the coupler. The MBT Headed Anchor also has the added advantage of requiring no special bar end preparation.

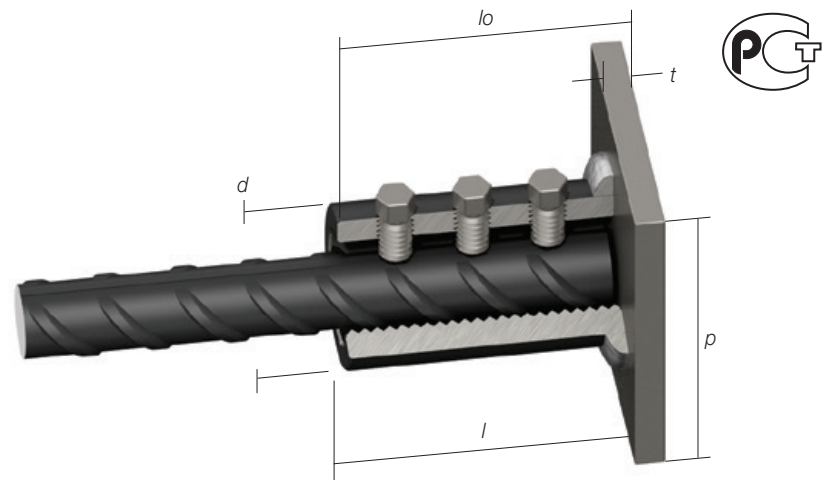

| Bar Diameter (mm)              | 10            | 12            | 14            | 16            | 18            | 20            | 22            | 25            | 26            | 28            | 30            | 32            | 34            | 36            | 40            |
|--------------------------------|---------------|---------------|---------------|---------------|---------------|---------------|---------------|---------------|---------------|---------------|---------------|---------------|---------------|---------------|---------------|
| External Diameter (mm)         | $d$ 33        | 33            | 42            | 42            | 48            | 48            | 48            | 54            | 67            | 67            | 71            | 71            | 75            | 85            | 81            |
| Coupler Length (mm)            | $l$ 55        | 75            | 82            | 82            | 104           | 104           | 126           | 129           | 156           | 156           | 156           | 156           | 215           | 247           | 247           |
| Total Length (mm)              | $lo$ 65       | 85            | 92            | 92            | 114           | 114           | 136           | 139           | 168           | 168           | 171           | 171           | 230           | 262           | 262           |
| Plate Thickness (mm)           | $t$ 10        | 10            | 10            | 10            | 10            | 10            | 10            | 10            | 12            | 12            | 15            | 15            | 15            | 15            | 15            |
| Plate w x h (mm)               | $p$ 70        | 70            | 70            | 80            | 90            | 90            | 90            | 100           | 110           | 110           | 130           | 130           | 130           | 150           | 150           |
| Socket Size A/F (ins)          | $\frac{1}{2}$ | $\frac{1}{2}$ | $\frac{1}{2}$ | $\frac{1}{2}$ | $\frac{1}{2}$ | $\frac{1}{2}$ | $\frac{1}{2}$ | $\frac{5}{8}$ | $\frac{5}{8}$ | $\frac{5}{8}$ | $\frac{5}{8}$ | $\frac{5}{8}$ | $\frac{3}{4}$ | $\frac{3}{4}$ | $\frac{3}{4}$ |
| No of Bolts                    | 2             | 3             | 3             | 3             | 4             | 4             | 5             | 4             | 5             | 5             | 5             | 5             | 6             | 7             | 7             |
| Approx Weight (kg)             | 0.64          | 0.74          | 1.01          | 1.07          | 1.58          | 1.58          | 1.72          | 2.29          | 3.81          | 4.14          | 5.08          | 4.72          | 5.17          | 9.13          | 8.30          |
| Part No.<br>(No hole in plate) | ETHA10        | ETHA12        | ETHA14        | ETHA16        | ETHA18        | ETHA20        | ETHA22        | ETHA25        | ETHA26        | ETHA28        | ETHA30        | ETHA32        | ETHA34        | ETHA36        | ETHA40        |
| Part No.<br>(Hole in plate)    | ETHA10H       | ETHA12H       | ETHA14H       | ETHA16H       | ETHA18H       | ETHA20H       | ETHA22H       | ETHA25H       | ETHA26H       | ETHA28H       | ETHA30H       | ETHA32H       | ETHA34H       | ETHA36H       | ETHA40H       |

**Note:** Minimum compressive strength of concrete 25N/mm<sup>2</sup>. Dimensions are nominal values and subject to change from time to time.



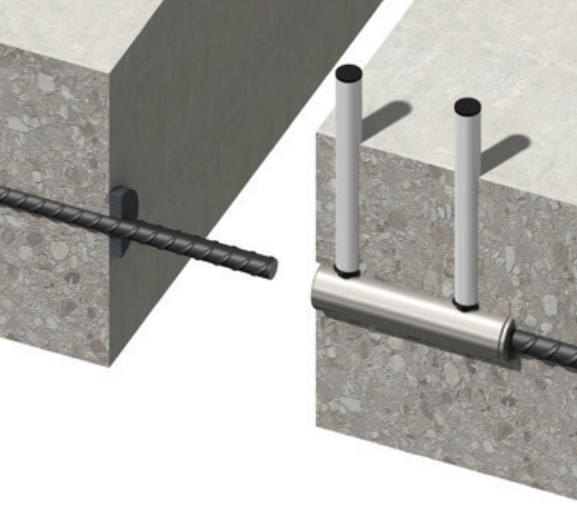

## HM Grout Sleeve Couplers

Ancon HM Grout Sleeves have been designed to cater for the rebar tolerances / bar alignment issues associated with joining precast concrete elements together.

The range comprises two standard coupler types: full-grout sleeves and half-grout sleeves. In the first, bars are simply inserted to meet at the nominal centre point of the sleeve. In the latter, one end features an internal thread to accept a pre-threaded bar while the other is open to accommodate a non-threaded continuation bar. The standard internal thread suits Ancon Bartec Plus parallel-threaded rebars. Other thread profiles are available.



HM Full-Grout and HM Half-Grout Sleeves

These sleeves are manufactured from high strength ductile iron and used with our high performance, shrinkage-compensated cementitious grout.

Tests show compliance with the rebar coupler performance specifications in BS 8597 and ISO 15835.

Contact us for full technical details or download the product brochure online.

## Other Leviat Products

### Reinforcement Continuity Systems

Reinforcement Continuity Systems are an increasingly popular means of maintaining continuity of reinforcement at construction joints in concrete. Our re-bend systems consist of pre-bent bars housed within a steel casing. Once installed, the bars are straightened ready for lapping with slab reinforcement. A range of headed anchors and starter bars is also available, which once cast in concrete will accept threaded continuation bars. They easily accommodate long lap lengths such as those prevalent in EC2, and eliminate the need for on-site bar straightening. Headed anchors are particularly useful when it comes to minimising rebar congestion in the wall.



### Shear Load Connectors

Shear Load Connectors are used to transfer shear across expansion joints and contraction joints in concrete. They are more effective at transferring loads and allowing movement to take place than standard dowels. The range features rectangular box section sleeves to allow lateral movements in addition to longitudinal movements. A range of lockable dowels is available for temporary movement joints in post-tensioned concrete.



### Channel and Bolt Fixings

Leviat offers a wide range of channels and bolts in order to fix items such as fabricated steel masonry supports and restraints to structural frames. Cast-in channels and expansion bolts are used for fixing to the edges of concrete floors and beams.



### Punching Shear Reinforcement

Punching shear reinforcement systems are used within a slab to provide additional reinforcement and prevent punching shear around columns. The systems generally consists of double-headed studs welded to flat rails, and are designed to suit the load conditions and slab depth at each column location using free-to-download calculation software.



### Structural Thermal Breaks

Structural thermal breaks minimise heat loss while maintaining structural integrity: for example at balcony locations in externally insulated and cavity insulated buildings, or at slab-to-wall connections in internally insulated buildings. As a critical structural component they transfer moment, shear, tension and compression forces. Standard solutions are available for concrete-to-concrete, steel-to-concrete and steel-to-steel interfaces.







**Leviat<sup>®</sup>**  
A CRH COMPANY

Innovative engineered products and construction solutions that allow the industry to build safer, stronger and faster.





## Worldwide contacts for Leviat:

### Australia

**Leviat**  
98 Kurrajong Avenue,  
Mount Druitt Sydney, NSW 2770  
Tel: +61 - 2 8808 3100  
Email: info.au@leviat.com

### Austria

**Leviat**  
Leonard-Bernstein-Str. 10  
Saturn Tower, 1220 Wien  
Tel: +43 - 1 - 259 6770  
Email: info.at@leviat.com

### Belgium

**Leviat**  
Borkelstraat 131  
2900 Schoten  
Tel: +32 - 3 - 658 07 20  
Email: info.be@leviat.com

### China

**Leviat**  
Room 601 Tower D, Vantone Centre  
No. A6 Chao Yang Men Wai Street  
Chaoyang District  
Beijing · P.R. China 100020  
Tel: +86 - 10 5907 3200  
Email: info.cn@leviat.com

### Czech Republic

**Leviat**  
Business Center Šafránková  
Šafránková 1238/1  
155 00 Praha 5  
Tel: +420 - 311 - 690 060  
Email: info.cz@leviat.com

### Finland

**Leviat**  
Vädursgatan 5  
412 50 Göteborg / Sweden  
Tel: +358 (0)10 6338781  
Email: info.fi@leviat.com

### France

**Leviat**  
6, Rue de Cabanis  
FR 31240 L'Union  
Toulouse  
Tel: +33 - 5 - 34 25 54 82  
Email: info.fr@leviat.com

### Germany

**Leviat**  
Liebigstrasse 14  
40764 Langenfeld  
Tel: +49 - 2173 - 970 - 0  
Email: info.de@leviat.com

### India

**Leviat**  
309, 3rd Floor, Orion Business Park  
Ghodbunder Road, Kapurbawdi,  
Thane West, Thane,  
Maharashtra 400607  
Tel: +91 - 22 2589 2032  
Email: info.in@leviat.com

### Italy

**Leviat**  
Via F.lli Bronzetti 28  
24124 Bergamo  
Tel: +39 - 035 - 0760711  
Email: info.it@leviat.com

### Malaysia

**Leviat**  
28 Jalan Anggerik Mokara 31/59  
Kota Kemuning, 40460 Shah Alam  
Selangor  
Tel: +603 - 5122 4182  
Email: info.my@leviat.com

### Netherlands

**Leviat**  
Oostermaat 3  
7623 CS Borne  
Tel: +31 - 74 - 267 14 49  
Email: info.nl@leviat.com

### New Zealand

**Leviat**  
2/19 Nuttall Drive, Hillsborough,  
Christchurch 8022  
Tel: +64 - 3 376 5205  
Email: info.nz@leviat.com

### Norway

**Leviat**  
Vestre Svanholmen 5  
4313 Sandnes  
Tel: +47 - 51 82 34 00  
Email: info.no@leviat.com

### Philippines

**Leviat**  
2933 Regus, Joy Nostalg,  
ADB Avenue  
Ortigas Center  
Pasig City  
Tel: +63 - 2 7957 6381  
Email: info.ph@leviat.com

### Poland

**Leviat**  
Ul. Obornicka 287  
60-691 Poznan  
Tel: +48 - 61 - 622 14 14  
Email: info.pl@leviat.com

### Singapore

**Leviat**  
14 Benoi Crescent  
Singapore 629977  
Tel: +65 - 6266 6802  
Email: info.sg@leviat.com

### Spain

**Leviat**  
Polígono Industrial Santa Ana  
c/ Ignacio Zuloaga, 20  
28522 Rivas-Vaciamadrid  
Tel: +34 - 91 632 18 40  
Email: info.es@leviat.com

### Sweden

**Leviat**  
Vädursgatan 5  
Grenzstrasse 24  
Tel: +46 - 31 - 98 58 00  
Email: info.se@leviat.com

### Switzerland

**Leviat**  
Hertistrasse 25  
3250 Lyss  
Tel: +41 - 31 750 3030  
Email: info.ch@leviat.com

### United Kingdom

**Leviat**  
President Way, President Park,  
Sheffield, S4 7UR  
Tel: +44 - 114 275 5224  
Email: info.uk@leviat.com

### United States of America

**Leviat**  
6467 S Falkenburg Rd.  
Riverview, FL 33578  
Tel: (800) 423-9140  
Email: info.us@leviat.us

### For countries not listed

Email: info@leviat.com

**Leviat.com**

#### Notes regarding this catalogue

© Protected by copyright. The construction applications and details provided in this publication are indicative only. In every case, project working details should be entrusted to appropriately qualified and experienced persons. Whilst every care has been exercised in the preparation of this publication to ensure that any advice, recommendations or information is accurate, no liability or responsibility of any kind is accepted by Leviat for inaccuracies or printing errors. Technical and design changes are reserved. With a policy of continuous product development, Leviat reserves the right to modify product design and specification at any time.

# Leviat®

A CRH COMPANY

For more information on these products, contact:

**Leviat**

President Way  
President Park  
Sheffield, S4 7UR  
United Kingdom

Tel: +44 (0) 114 275 5224

Fax: +44 (0) 114 276 8543

Email: [info.ancon.uk@leviat.com](mailto:info.ancon.uk@leviat.com)

For sales enquiries:

Email: [reinforcement.uk@leviat.com](mailto:reinforcement.uk@leviat.com)

[Ancon.co.uk](http://Ancon.co.uk)

[Leviat.com](http://Leviat.com)

**Imagine. Model. Make.**

**[Leviat.com](http://Leviat.com)**