

Installation Instructions

FS Expansion Joint Covers, Generation X

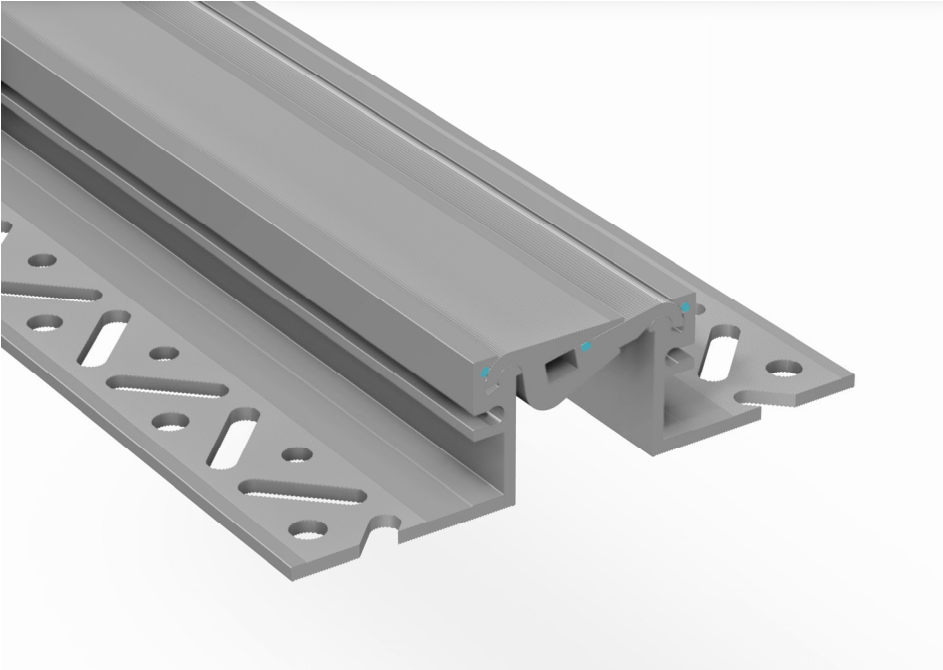

Example of an asymmetrical cover construction

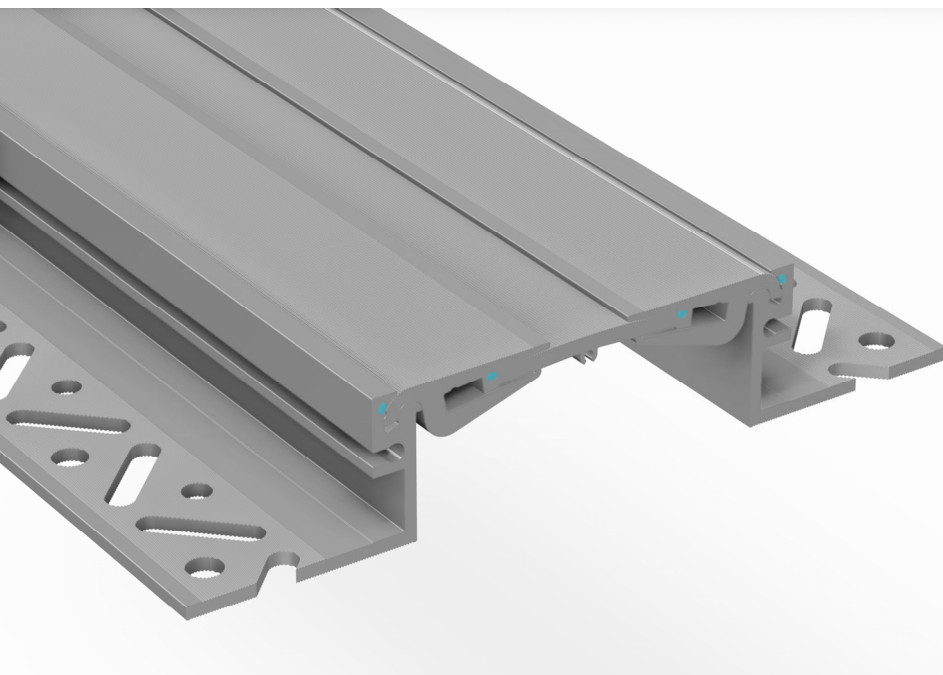

Example of a symmetrical cover construction

Scope of use

The installation of the MIGUTRANS heavy duty expansion joint covers FSX in the new industrial design covers is, in principle, identical and will be shown using the joint cover FSX 75 as an example.

This applies accordingly to the following joint covers, too:

- FSX 75
- FSX 110
- FSX 130
- FSX 146
- FSX 160

Further expansion joint covers of the current FS-series will be converted into the FSX construction series in the future. The procedure applies to these covers correspondingly.

The mounting of expansion joint covers is by default effect with screw anchors type MMS-plus of the company Heco. For alternative screw anchors please refer to the list of standard mountings on our website.

Please read the following installation thoroughly instructions before starting installation work. In case of any queries, please do not hesitate to contact our MIGUA service team at +49 (0)2058 / 774-0 or info@migua.de.

For further technical data please visit migua.com

MIGUTRANS

1. General Information

Please check whether the supplied material is complete and undamaged prior to starting with the installation. Any damage or missing components must be reported to MIGUA without delay.

Please make sure that the material and the on-site characteristics correspond to the technical data provided in the datasheet. Pay particular attention to the existing joint width. It must not be larger than the maximum joint width specified in the technical data of the expansion joint cover.

Check the previous work carried out by other workers to ensure correct and accurate execution. Please make sure, in particular, that the cut-out has the correct width, that the surface is capable of supporting the pay-load, that it is free of cracks and the that cover joint flanks show no signs of break-out. The maximum permitted joint width of the cover must not be exceeded, even when taking the deviation of the linearity of the joint into account.

The cut-out should be 100mm wider than the overall cover width. For details, please see the technical data sheet of the respective cover.

Please coordinate the height of the installed cover (upper edge of cover) with the construction site management.

2. Preparation

The concrete surface must be capable of carrying the payload and clean, dry as well as free of dust. The pressure resistance of the reinforced concrete must meet, at minimum, that of C20/25. Before installation, the cover is to be cleaned of dirt, oils and grease using a cleaning/solvent solution which leaves no residues. In order to ensure that the smoothing material does not enter the joint, the joint plate must protrude out of the joint by the same thickness as the smoothing material. Please place the MIGUTRANS expansion joint cover over the joint on the floor in order to familiarize yourself with the system and to check the correct dimensions. When using asymmetrical covers, please ensure that the covers are arranged in the same way. To make this clear, arrows are attached to the protective film on the covers. At cover joints, the cover on both sides of the joint must point in the same direction. Then store the covers alongside the joint.

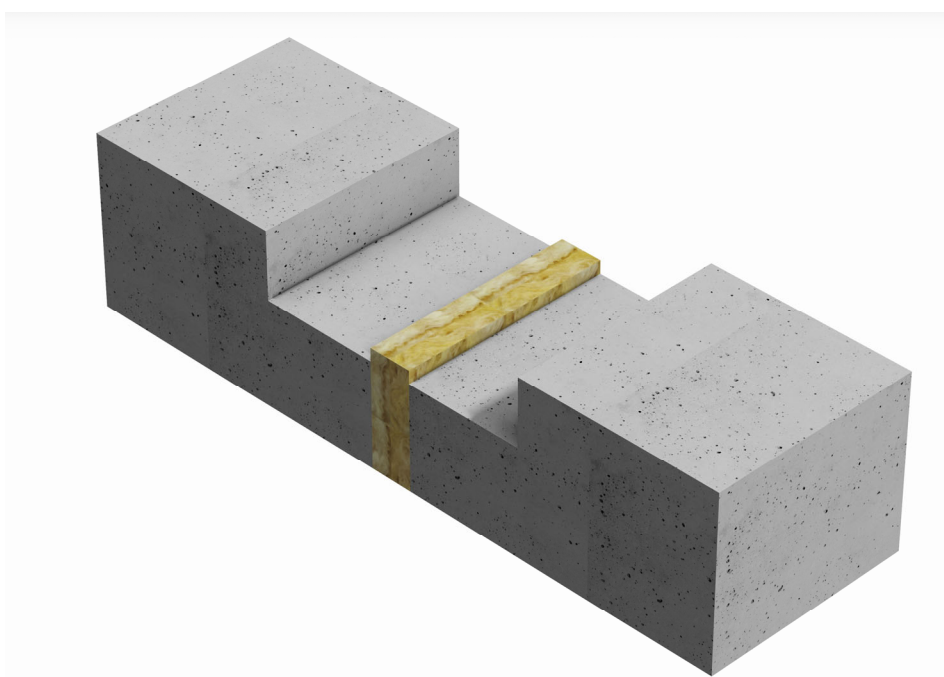

MIGUTRANS

3. Creating the leveling layer

In order to level any unevenness in the raw concrete surface, smoothing material must be applied to both sides of the joint. The width of the material must at minimum be as wide as the cover flank. A highly durable and loss-free PCC mortar, epoxy resin mortar or similar material must be used. The selection of the mortar has to be carried out in accordance with the on-site situation. Please pay attention to the application instructions provided by the manufacturer.

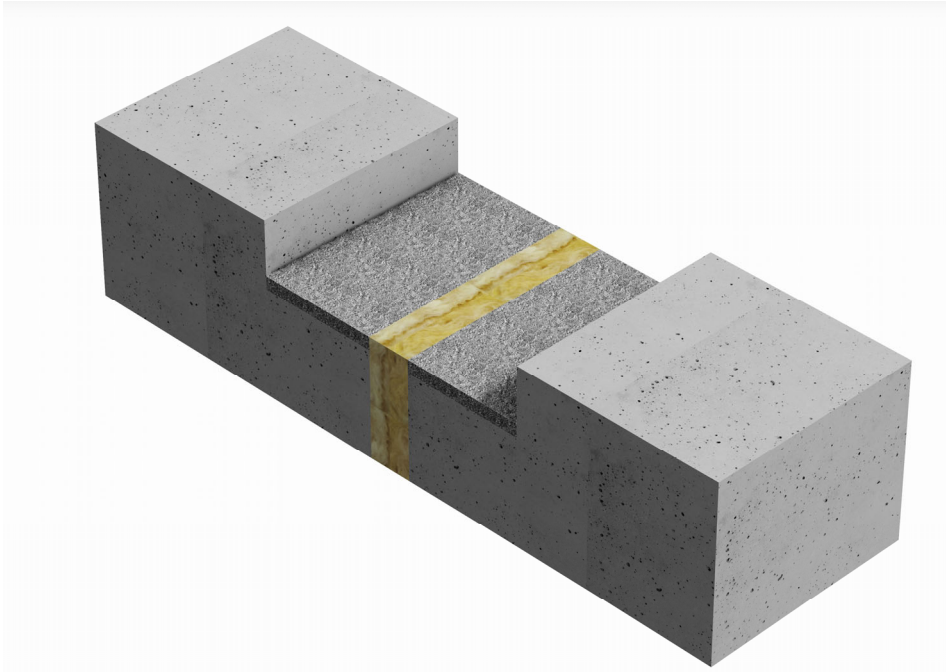

4. Setting the covers

In case of shaped elements, e.g. T-pieces or cross-pieces, laying should begin with these. Press the covers centrally arranged over the joint, to the right height, into the fresh mortar bed. Attention should be paid to ensure that the fixture flanks have no hollows and are fully lined. The fixture flanks must not reach into the joint.

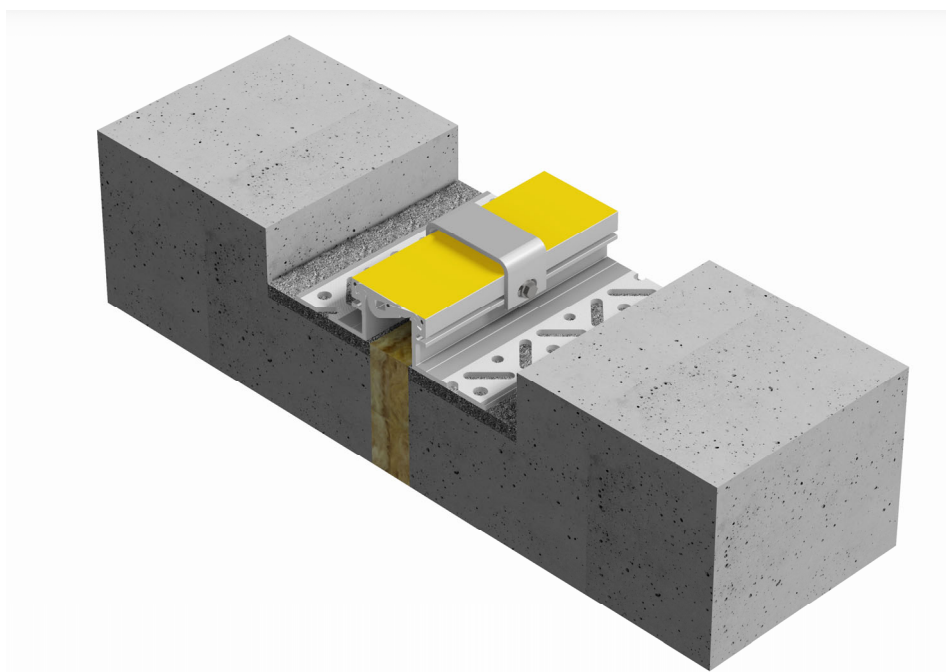

5. Connecting individual lengths

For the majority of cover constructions, the correct height and flush connection of individual lengths is carried out using connecting pins which are fitted into the provided channels. For some cover constructions, the joint cover cap and basic construction are shifted against one another to ensure safe connection by pushing the individual lengths together.

While installing asymmetrical covers, please make sure that the covers are arranged alike. Protective films with respective arrows have been fixed to the covers for clarification.

At joint cover joints, both covers have to point in the same direction.

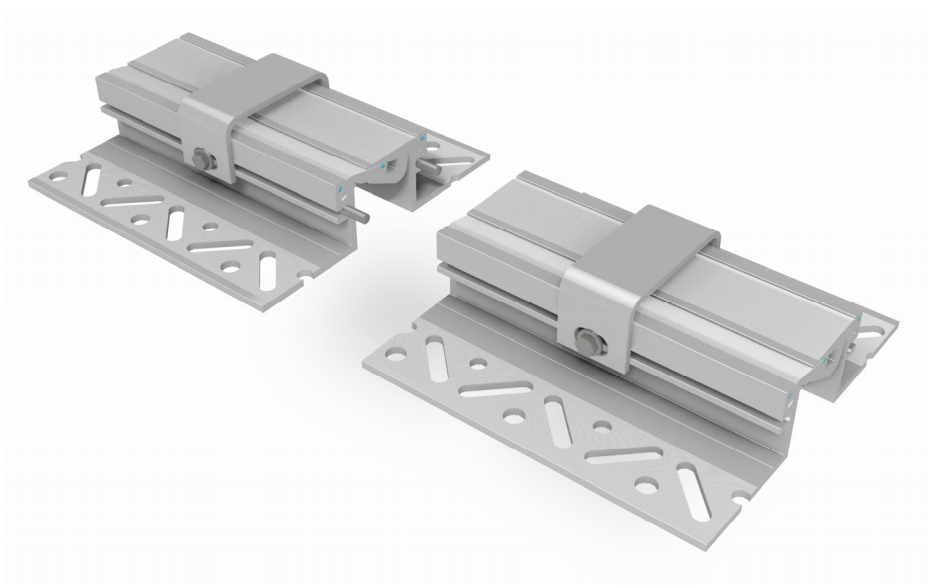

6. Anchoring in X-mounting matrix®

The X-mounting matrix provides variable possibilities of anchoring, in order to be able to avoid disturbing reinforcement while setting anchors. For that purpose, please use the long bore holes with 9 mm diameter. The other bore holes (\varnothing 9mm on the inside, \varnothing 11mm on the outside) meet the requirements of the below mentioned anchor to ensure the minimum distance to the concrete edge. When using composite anchors, please use the outer mounting holes. In general, anchoring should be effected as far outside as possible. When using countersunk screws, the holes in the mounting brackets must be countersunk, too.

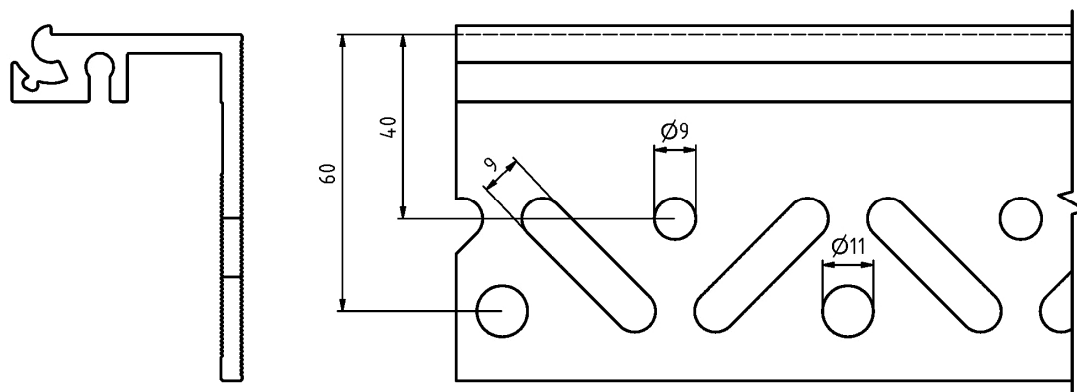

7. Anchoring of covers

After the mortar has hardened, the fixture flanks of the cover are anchored laterally to the expansion joint vibration-free into the raw concrete surface. For this, please use mortar screws Heco MMS-plus SS 10 X 90 vz or an alternative anchor as published in our standard mounting list on our website. The length of the anchor is based on the required strength (mortar layer plus cover flank strength). When using countersunk screws, the holes of the cover flank must be countersunk accordingly. The anchoring is carried out at intervals of 300 mm. Please ensure vertical application of the impact screwdriver. The regulations set out by the screw manufacturer are to be observed. The clamping strengths and installation depths of the anchor manufacturer must be maintained.

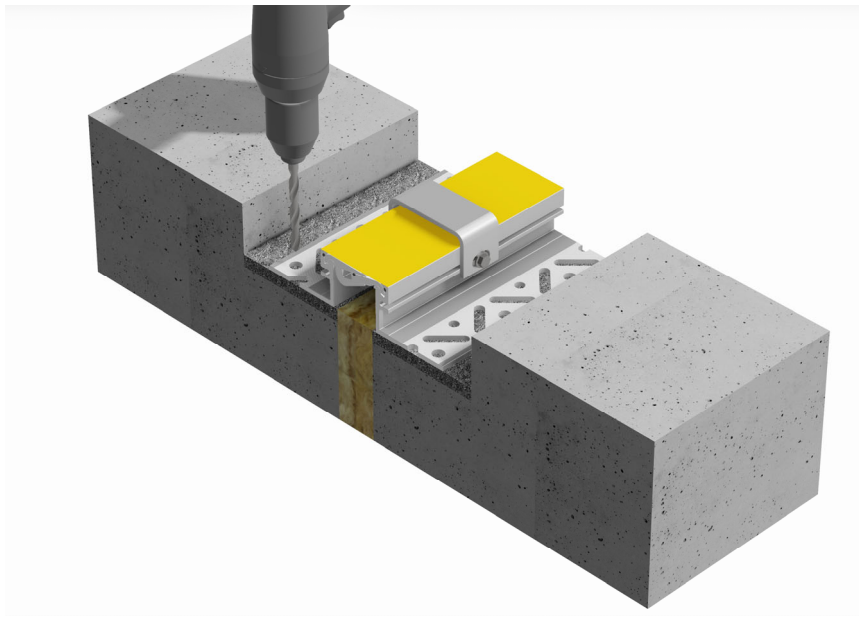

8. Removing the spacers

The factory-mounted spacers are to be removed immediately after the covers are attached. The spacers may look differently depending on the individual cover. (see item 7).

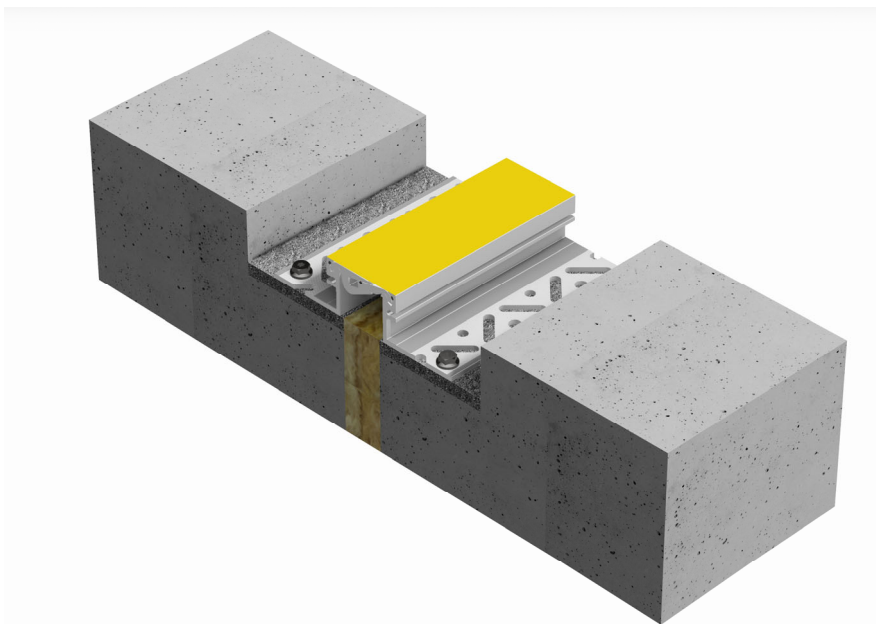

MIGUTRANS

9. Filling the cut-out/processing the cover

In the case of fixture in a cut-out:

Filling the cut-out with suitable material

Here, attention is to be paid to the subsequent application, e.g. loads caused by forklifts, abrasion, chemicals etc. The filling level is to be determined by the construction site management whilst taking into account the subsequent flooring.

In the case of fixture without a cut-out :

Processing of flooring/floor surface

In any case, attention is to be paid to ensure that the upper edge of the neighboring surface has the same height as the upper edge of the cover. **The cover's upper edges must not protrude.**

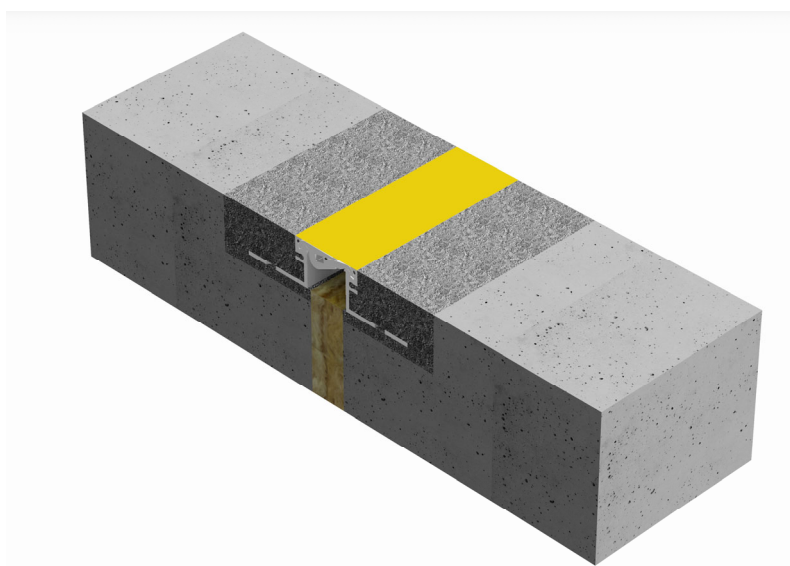

10. Removing the protective film

Shortly before acceptance of work by the client, please remove the protective film and clean the cover.

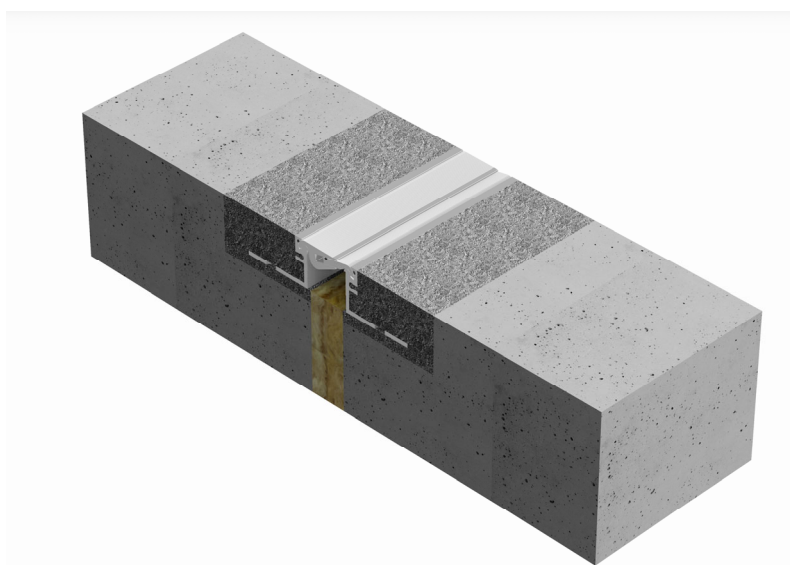

Given that qualitatively equivalent results are achieved otherwise, it is permitted to deviate from the described procedures.

For more information please visit migua.com